

Bicentennial Moment #6: Dr. Benjamin Swett (1771-1853): Physician and Inventor

Many Livingston County residents patented inventions in the nineteenth century. Among them was Dr. Benjamin Swett of Mt. Morris who, in 1845, invented what he called "a new and useful mode of delivering Medicated Fume-Baths." In essence, it was a large wooden box in which a person would sit with a stove attached. A connecting pipe delivered hot "medicated vapors" without the presence of steam.

Others had patented similar baths, but Dr. Swett claimed his design to be the most superior in the world as a remedy for numerous afflictions, from rheumatism to "female complaints." Dr. Swett sold the bath at several locations in Rochester in the early 1850s, but sales were short-lived as he passed away in 1853. It is unclear whether the machine was considered safe or a fire hazard.

B. Swett,
Taylor Bath.
No. 347. Patented Dec. 31, 1845.

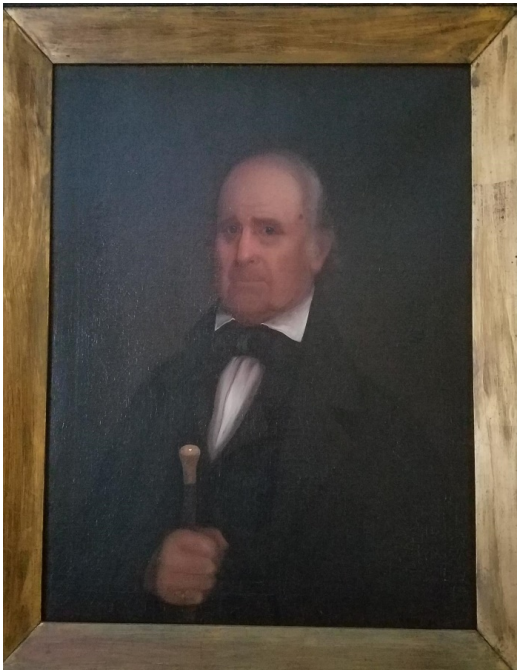
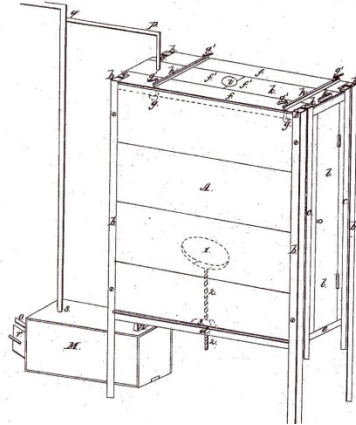

Water therapy advanced in popularity in the U. S. and around the world throughout the 1800s, thanks in large part to the contributions of Dr. James C. Jackson and Dr. Harriet Austin at the Jackson Sanitarium in Dansville.

Dr. Swett (portrait in County Historian's Collection)